



**MODEL 2020
SINGLE LEVER,
DUAL FUNCTION,
MULTI ENGINE
CONTROL HEAD**

This assembly demonstrates how three 2020 control heads are put together for a three-engine application.

Other configurations are also available.

The 2020 Control Head offers more features than any other control of this type in the world. It was designed for dual function (clutch and throttle), single lever mechanical controls.

It is constructed entirely in bronze and stainless steel with a low profile dome per our customers' requests. The mechanical output portion is on a swivel base allowing the cables to be mounted in any of the three downward positions. Extremely robust in construction, it is intended for the most demanding applications.

This control head is available in multi-engine configuration whereas the controls can be mounted side by side as shown in the picture above for a three engine application and for most cable sizes. The number of controls that can be stacked together is virtually unlimited.

Options available:

- H with one neutral safety switch
- J with two neutral safety switches
- K chrome finish
- L polished bronze finish
- MM epoxy black finish
- WW white finish
- ZZ brushed aluminum finish

Ordering Information

Please specify number of engines (handles) and metal surface finish.

Example: 2020-K2 for two engines with chrome finished handles and cover.

Connection Kits available:

- 2020-0901 for 30 series cables
- 2020-0902 for 40 series cables

MODEL 2020

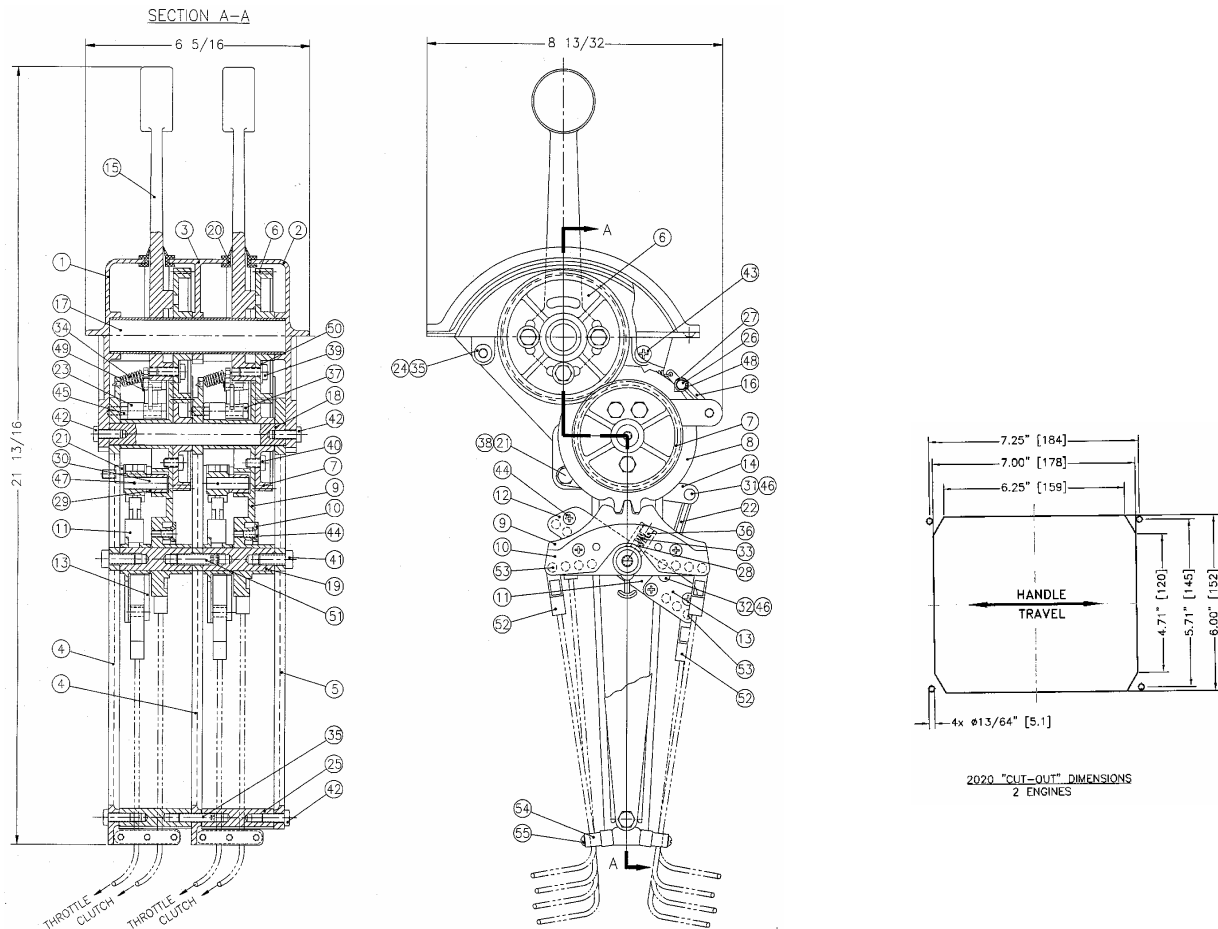

2020 "CUT-OUT" DIMENSIONS
2 ENGINES

ITEM	QTY	PART NO.	DESCRIPTION	ITEM	QTY	PART NO.	DESCRIPTION
1	1	2020-0001	Dome, left	25	2	2020-0024	Spacer, bottom
2	1	2020-0002	Dome, right	25*	1	2020-1024	Spacer (single engine)
3	1	2020-0003	Dome, centre	26	2	2020-0025	Snap Ring Pin
4	2	2020-0004	Support, left	27	2	2020-0026	Detent Roller
5	1	2020-0005	Support, right	28	2	2542-0008	Friction Plug
6	2	2020-0006	Drive Gear	29	2	2046-0027	Throttle Roller
7	2	2020-0007	Driven Gear	30	2	2046-0023	Roller Pin
8	2	2020-0008	Cam	31	2	2047-0019	Pin
9	2	2020-0009	Clutch Pivot Plate	32	2	2047-0020	Pin
10	2	2020-0010	Retainer	33	2	1201-0002	Spring
11	2	2020-0011	Throttle Pivot Plate	34	2	1202-0005	Spring
12	2	2020-0012L	Pin Retainer, left	35	3	1016-1016	Hex Socket Set Screw
13	2	2020-0012R	Pin Retainer, right	36	2	1016-1204	Hex Socket Set Screw
14	2	2020-0013	Link Arm #1	37	2	1001-1024	Hex Hd Cap Screw
15	2	2020-0014	Handle	38	2	1001-1020	Hex Hd Cap Screw
16	2	2020-0015	Detent Arm	39	6	1001-1006	Hex Hd Cap Screw
17	1	2020-0016	Tubing Shaft	40	6	1001-1008	Hex Hd Cap Screw
17*	1	2020-1016	Shaft (single engine)	41	2	1001-1112	Hex Hd Cap Screw
18	1	2020-0017	Bearing, top	42	6	1001-1010	Hex Hd Cap Screw
18*	1	2020-1017	Bearing (single engine)	43	4	1009-1010	Flat Hd Phillips Cap Screw
19	2	2020-0018	Bearing, bottom	44	12	1009-0808	Flat Hd Phillips Cap Screw
19*	1	2020-1018	Bearing (single engine)	45	2	1022-0110	Nut
20	2	2020-0019	Rubber Boot	46	4	1024-0508	Spring Pin
21	2	2020-0020	Shoulder Bushing	47	2	1024-0510	Spring Pin
22	2	2020-0021	Link Arm #2	48	2	1029-1025	Snap Ring
23	2	2020-0022	Spacer	49	2	1029-2025	Snap Ring
24	4	2020-0023	Spacer, top	50	6	1023-0110	Washer
24*	2	2020-1023	Spacer (single engine)	51	1	1016-1120	Hex Socket Set Screw

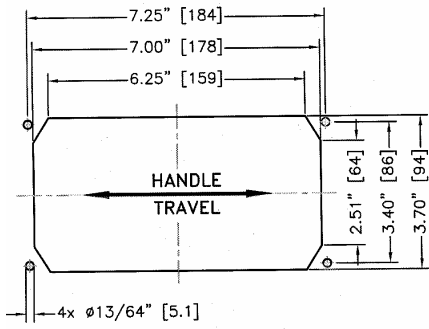

2020 "CUT-OUT" DIMENSIONS
1 ENGINE

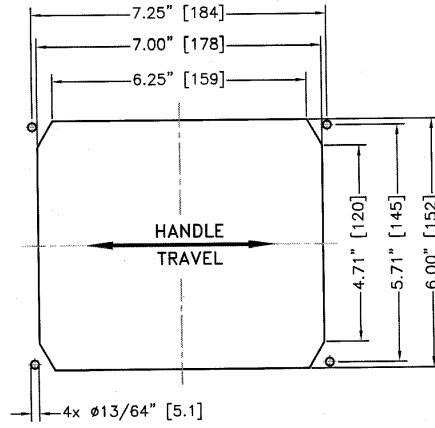

2020 "CUT-OUT" DIMENSIONS
2 ENGINES

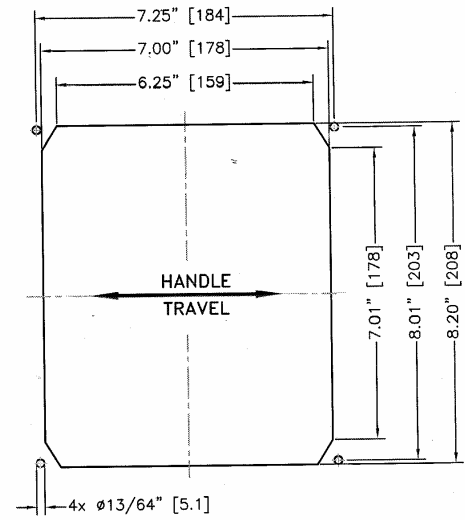

2020 "CUT-OUT" DIMENSIONS
3 ENGINES