

2046 | PUSH-PULL CONTROL



Putting you in control.

Manufactured for the marine environment, the Kobelt 2046 push-pull control is the rugged solution for your vessel. The single-engine control head features the clutch and throttle control integrated into a single lever. The Kobelt 2046 control head also features a spring-loaded throttle override which permits running the engine with the clutch disengaged. With a wide array of options to choose from, Kobelt has the product to meet your propulsion control needs.

Specifications

Handle Travel:

• Neutral:	0°	Detented
• Clutch engage:	+/- 30°	Detented
• Full throttle:	+/- 85°	-
• Over-travel: ¹	92°	Detented

Pin Position Stroke:

	1	2	3	4
• Clutch:	±0.66 in [±17 mm]	±0.93 in [±24 mm]	±1.20 in [±30 mm]	±1.48 in [±38 mm]
• Throttle:	0.86 in [22 mm]	1.21 in [31 mm]	1.55 in [39 mm]	1.90 in [48 mm]

Maximum Output Force:²

	1	2	3	4
• Clutch:	147 lbf [654 N]	106 lbf [472 N]	83 lbf [369 N]	68 lbf [302 N]
• Throttle:	121 lbf [539 N]	90 lbf [399 N]	71 lbf [315 N]	59 lbf [261 N]

Lever Ratio:

	1	2	3	4
• Clutch:	5.1:1	3.7:1	2.9:1	2.4:1
• Throttle: ³	4.2:1	3.1:1	2.4:1	2.0:1

Ambient Temperature: -40°F...+140°F [-40 °C... + 60 °C]

Weight: 8.0 lbs [3.6 kg]

Key Features

- Throttle override capability
- Selectable strokes (4 positions)
- Suitable for 30 & 40 series cable
- Configurable design to suit requirements
- Bronze & stainless steel construction

¹ Forward direction only.

² Estimated output force is at end of stroke based on an input force of 29lbf on a "Tee" handle. Output force must not exceed rated cable force.

³ At end of stroke, lever ratio increases towards neutral.

SPECIFICATIONS

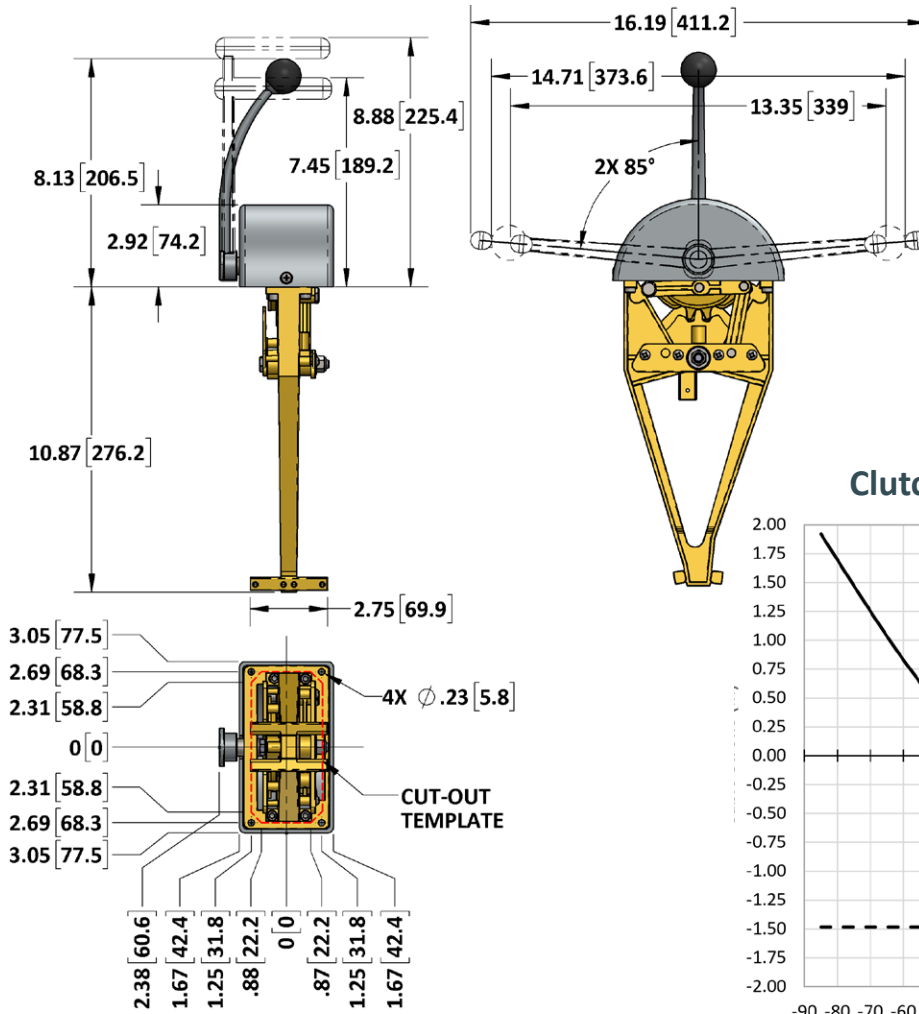

Clutch & Throttle Engagement

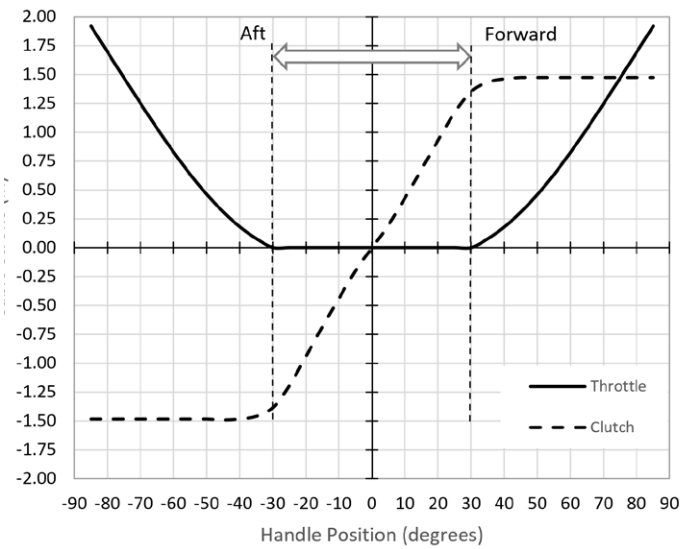

Model Code Key

2046-□□□ (list in alphabetical order)

Safety Options

- H = Neutral safety switch
- Blank = No safety option

Finish Options

- K = Chrome plated
- L = Polished brass
- M = Black painted dome & chrome plated handle
- Z = Metal position label

Handle Options

- U = Curved handle with knob
- V = Tee handle with plastic grip
- X = Short Tee handle
- Y = Long Tee handle

Popular Configurations

- 2046-KU
- 2046-KYZ

Accessories

- 2046-0901 Connector kit, 30 series cable
- 2046-0902 Connector kit, 40 series cable
- 2048-0903 Switch kit, neutral safety label; FWD – NEUTRAL - REV
- 2046-0015
- 2046-0905 Throttle extension kit; 30 series cable
- 2046-0906 Throttle extension kit; 40 series cable

Note: Cable kits must be ordered separately